

dv-LED displays..... The end of the projection era?

Christoph Bode
project: syntropy GmbH

project: syntropy GmbH – Specialized SI

Founded 2002, 20 employees

HQ and Workshop in Germany, Offices in Sweden & Singapore

- Visual Display Systems for Simulation & Training
- LED (Full dome) Displays for Simulation & Training
- Immersive XR Environments & XR-CAVEs
- Media Based Attractions & Immersive Spaces

We create highly immersive virtual environment – „Try Another World“

SYNTROPY

According to Erwin Schrödinger syntropy is understood as a process which exists in parallel to entropy.

Whereas entropy is the „negative“ force, which leads to formlessness and rigor in our universe, syntropy is the „positive“ creative force, which leads to increasingly complex life forms and thus to systems of higher order.



Flight Simulation | ATC Simulation



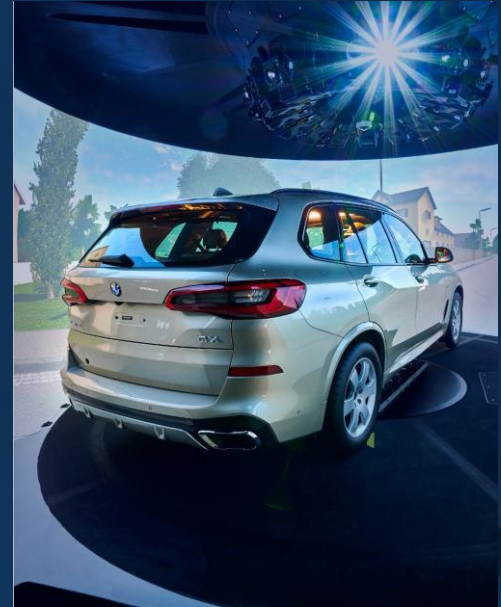

Driving Simulation | Ship Simulation |
Crane / Offshore Simulation

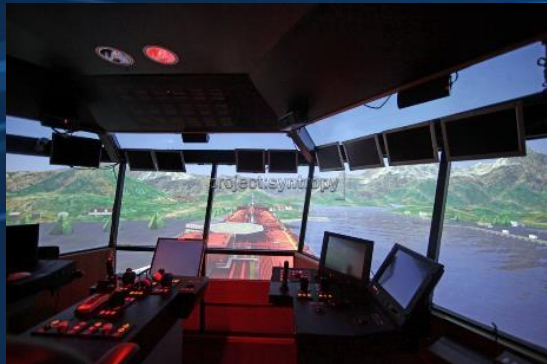

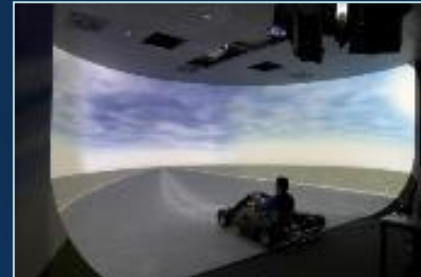
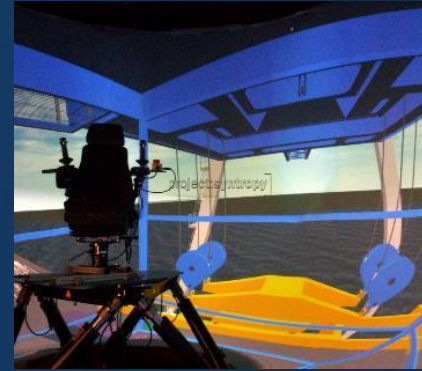
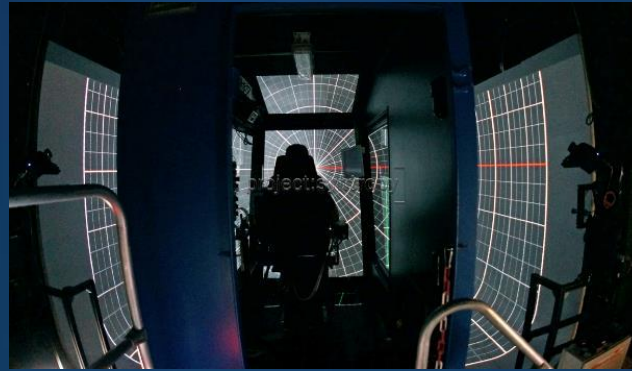

Simulation is endless....





LED Displays....

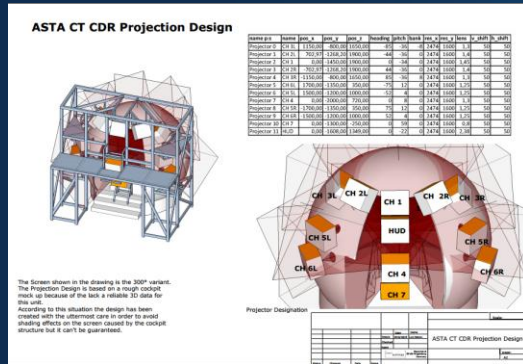

Visual Display Systems – Expertise

- Consultancy
- System Design & Engineering
- Technical planning, technical project management, implementation
- Turnkey delivery (from output graphics card including screen)

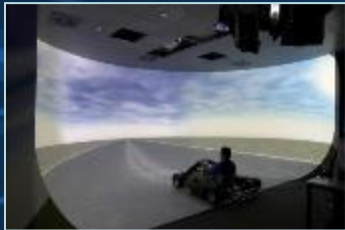

Visual Display Systems – Expertise

- In house Design tools
- In house Analysis tools
- Build on the knowledge of more than 15 years of delivering projects

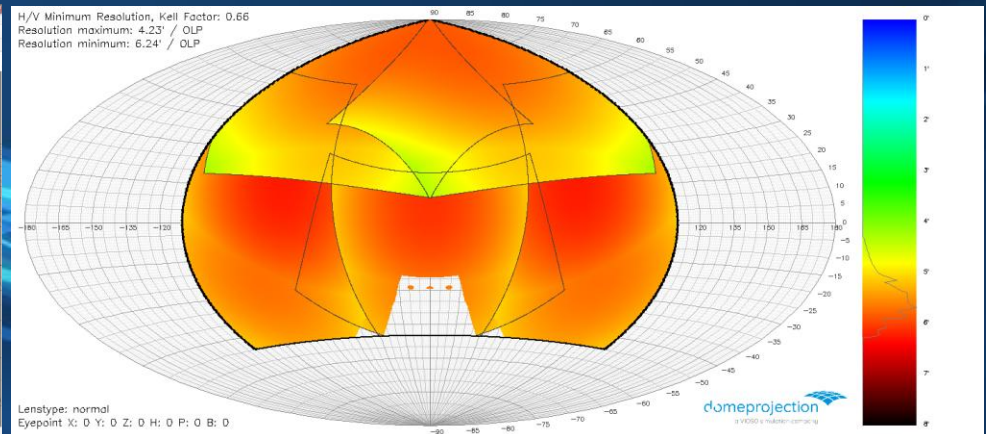
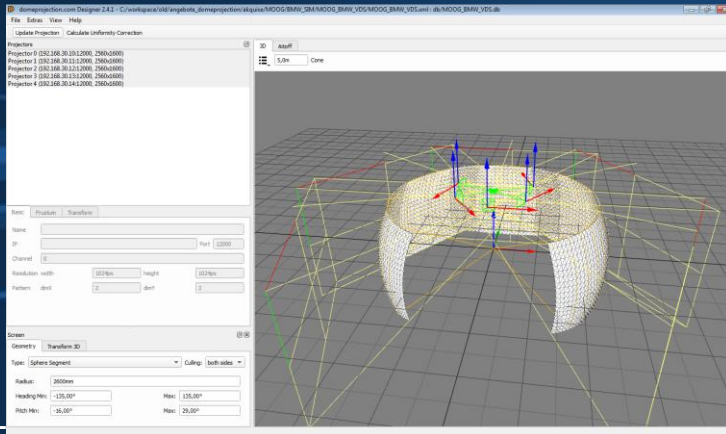
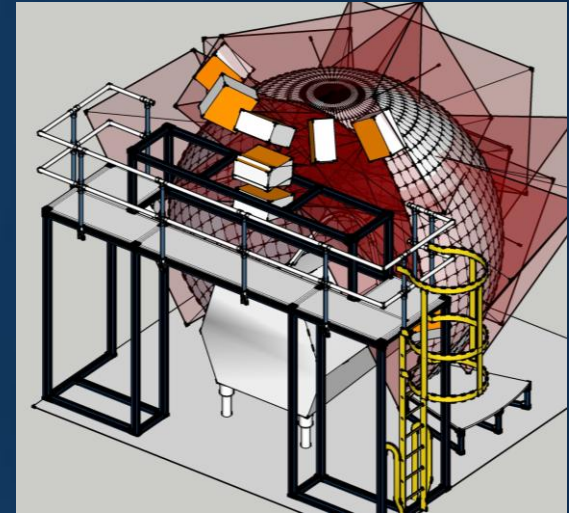

Visual Display Systems – Expertise

- COTS packages for mechanical design
- FEM and structural analysis
- AV planning and documentation tools
- Internal project management tools

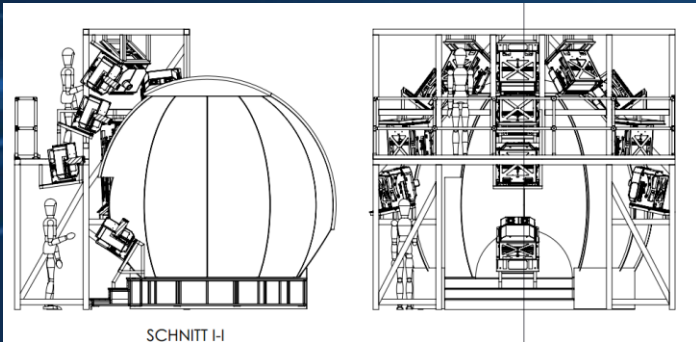
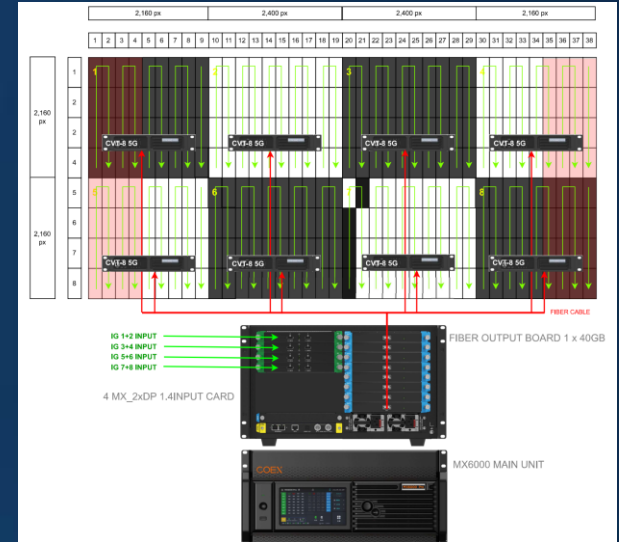

31.05.2020

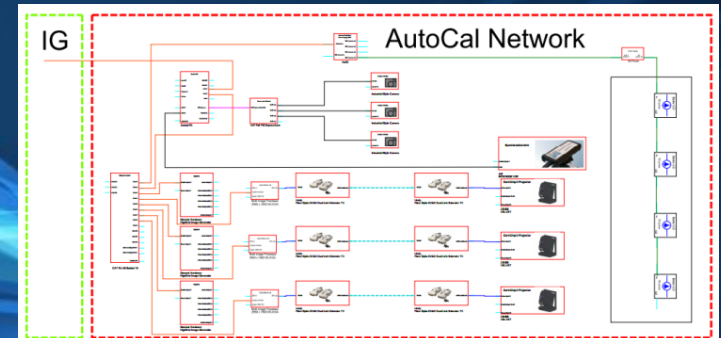
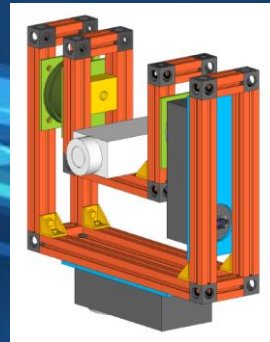

Visual Display Systems – Expertise



Factory and Workshop

- System profile machining
- Rack building
- Electrical & AV work shop
- FATs
- Testing

Fiber glass screen manufacturing
(external)

Visual Display Systems – Expertise



Factory & workshop

- System profile machining
- Rack building
- Electrical & AV work shop

Fiber glass screen manufacturing
(external)



Testing labs

- 2 dome systems,
- dark room for IR and night scenes)
- dv-LED Lab



Visual Display Technology Changes

- Lamp Based Projectors
- Solid State Illuminated Projectors
- Additionally, dv-LED technology
- Mix -Reality Technology



Driving Visual Display Technology

Driving new technologies through market demand, customer needs and innovation.





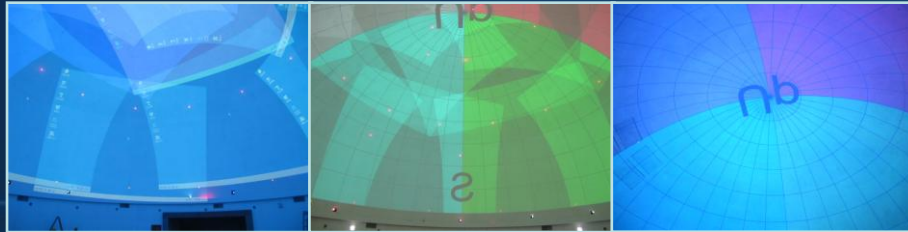















Exemplary:

- Camera based auto-calibration
- Real-time View Depended Warping
- Real-time View depend color shift correction



Overall Advantage of LED Technology

- More brightness, LED is ~ 12-15x brighter (5000ANSI, 25m², 0,8 gain)
- Higher Contrast
- Less real estate, no projection rig, structural support
- No or less control of environmental light
- Installation less time consuming
- No graphic loss due to overshoot and overlap (~30%)
- No calibration during installation or operation time
- Easy to service on site
- Standard support of high frame rate up to 240Hz
- Easy integration of access door and cabin replacement
- Less noisy

feature	projection	dvLED
High Resolution / low latency		
Contrast		
Ambient Light		
Colour Uniformity		
Viewing Angle		
Flexibility / shape of screen		
Installation Effort		
Maintenance		
Graphic Power Efficiency		
Power cons. / heat production		

Projection based technology has a right to play.....

- High Fidelity Simulation
- Dome or spherical screens
- Early development phase
- Concave screens
- ADAS –assistant systems
- HMI – control-concept
- Smaller Field-of-View
- Driver-in-the loop test
 - Steering
 - Recuperation
 - Break and acceleration tests
 - Artificial EV-sound

The answer is No

- dvLED is no longer an alternative technology in simulation — it is now a primary technology option.
- But projection is still the benchmark for some of the most demanding large-field, high-acuity simulation applications.

Thank you!

project: syntropy] GmbH

Klausenerstr. 47

D-39112 Magdeburg

Tel.: +49-391-63 60 66 44

FAX: +49-391-63 60 66 45

mailto: syntropians@project-syntropy.de

Web: www.project-syntropy.de

Youtube: www.youtube.com/user/Syntropian